

WEIGHING SCALES (BASIC TYPE)

- Double weighing pan in 430 stainless steel and plastic
- Zero-setting, weighing, subtracting tare value, simple counting
- Checking alarm, accumulation
- Peak (max.) and tracking mode
- LCD display, with backlight
- Unit: kg, g, t, lb, tj, hj, lb-oz



8007-6



alarm light (optional)



printer (optional)



large display (optional)

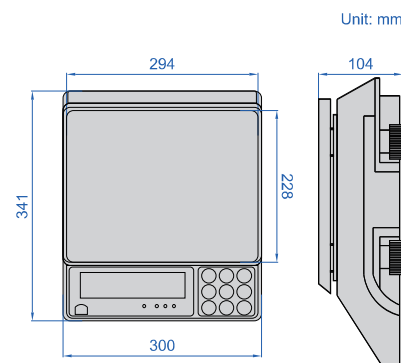

Unit: mm

SPECIFICATION

Code	8007-6	8007-15	8007-30	8007-6D	8007-15D	8007-30D
Weighing capacity	6kg	15kg	30kg	6kg	15kg	30kg
Minimal load	4g	10g	20g	4g	10g	20g
Readability (d)	0.2g	0.5g	1g	0.2g	0.5g	1g
Repeatability	±0.4g	±1g	±2g	±0.4g	±1g	±2g
Linearity	±1g	±2.5g	±5g	±1g	±2.5g	±5g
Stabilization time	2s					
Dimension of pan	294×228mm					
Output	no			RS232		
Operation temperature	0~40°C					
Operation humidity	≤85%RH					
Power supply	rechargeable lead acid battery (6V/4Ah)					
Dimension (L×W×H)	341×300×104mm					

OPTIONAL ACCESSORY (for scales with RS232)

Alarm light	customizable
Large display	8007-SCREEN
Printer	8391-PRN10